

Power Steering Pump — 5.4L

Special Tool(s)

 <p>ST1444-A</p>	<p>Installer Set, Teflon® Seal 211-D027 (D90P-3517-A) or equivalent</p>
---	---

Material

Item	Specification
<p>MERCON® V Automatic Transmission Fluid XT-5-QM (or XT-5-QMC) (US); CXT-5-LM12 (Canada)</p>	<p>MERCON® V</p>

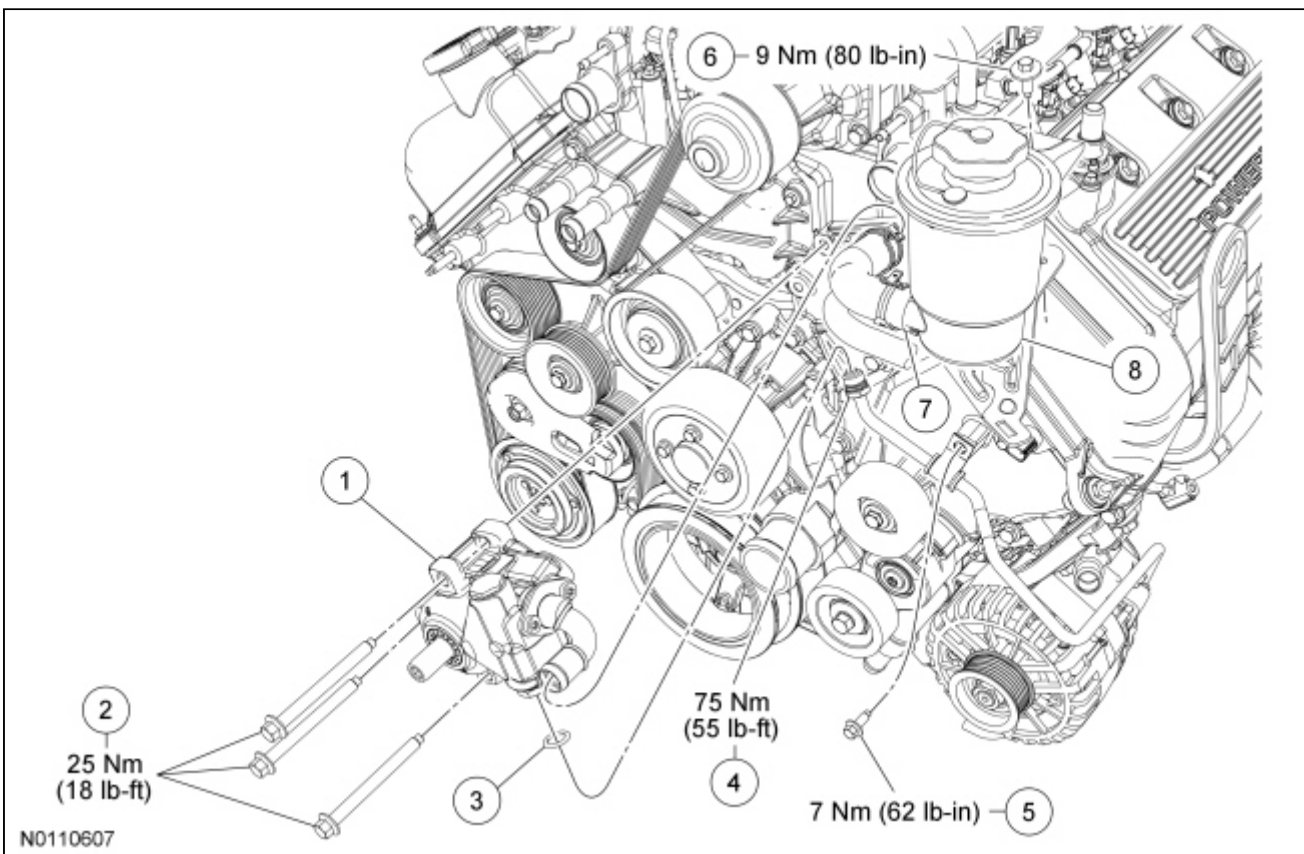

Item	Part Number	Description
1	3A674	Power steering pump
2	W700839	Power steering pump bolts (3 required)
3	388898	Teflon® seal
4	—	Pressure line-to-pump fitting (part of 3A719)
5	W505255	Pressure line bracket-to-engine bolt
6	W503924	Power steering fluid reservoir bolt

7	3691	Power steering pump supply hose
8	3A697	Power steering fluid reservoir

Removal and Installation

NOTICE: When repairing the power steering system, care should be taken to prevent the entry of foreign material or failure of the power steering components may result.

1. Remove the power steering pump pulley. For additional information, refer to [Power Steering Pump Pulley — 4.6L, 5.4L](#) in this section.
2. Using a suitable suction device, remove the power steering fluid from the fluid reservoir.
3. **NOTICE:** Make sure to remove the power steering reservoir bolt and separate the reservoir from the bracket or damage to the power steering reservoir may occur.

Remove the power steering fluid reservoir bolt and separate the reservoir from the power steering reservoir bracket.

- To install, tighten to 9 Nm (80 lb-in).
4. Release the clamp and disconnect the power steering pump supply hose from the power steering pump.
 - Position the power steering fluid reservoir aside.
 5. Remove the pressure line bracket-to-engine bolt.
 - To install, tighten to 7 Nm (62 lb-in).
 6. **NOTE:** A new Teflon® seal must be installed.

Disconnect the pressure line-to-pump fitting.

- Discard the Teflon® seal.
 - To install, tighten to 75 Nm (55 lb-ft).
7. Remove the 3 bolts and the power steering pump.
 - To install, tighten to 25 Nm (18 lb-ft).
 8. To install, reverse the removal procedure.
 9. **NOTE:** A new Teflon® seal must be installed.

Using the Teflon® Seal Installer Set, install a new Teflon® seal to the pressure line-to-pump fitting.

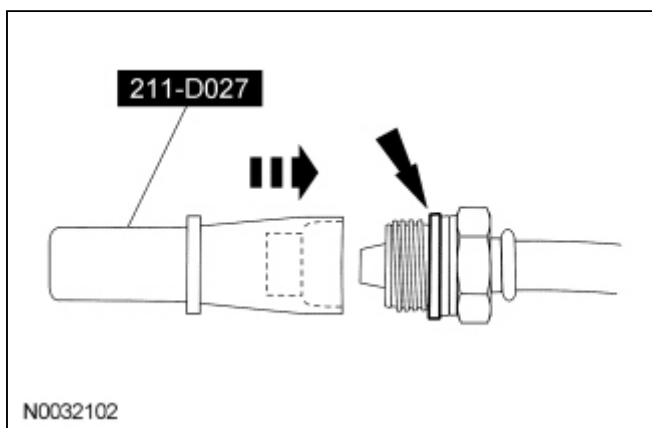

10. Fill the power steering system. For additional information, refer to [Section 211-00](#).

